

MODEL 69 UNIVERSAL PEENING TOOL

Operation Guide



OPERATION

AIR CONNECTION: The air inlet port of the tool should be connected by suitable flexible hose to an air supply between 85 and 95 PSIG. The fits and tolerances of the tool's parts are very fine and therefore the air used to drive the tool must be clean.

LUBRICATION: Each time the tool is used, a few drops of light, clean oil should be squirted into the valve port (located in the Nozzle) before the air hose is connected. Under no condition must the tool be used with dry air for any length of time. The Piston makes 6,000 strokes a minute inside the Nozzle and will "seize" within ten to twenty seconds if used without lubrication.

IT IS RECOMMENDED THAT THE TOOL BE USED WITH A FILTER — REGULATOR — LUBRICATOR ASSEMBLY IN THE AIR SUPPLY LINE.

MODES OF OPERATION: The Model 69 Universal Peening Tool comes fully assembled in Mode II; as shown in the drawing below. The Tool converts from Mode II to Mode I by simply reversing the Nut and the Piston Assembly. A wrench is provided for this purpose. The Tool can also be used for "bench" work in the tool room, as shown in Mode III. To convert from Modes I or II to Mode III the Crank was replaced by the Handle and attached to the Piston Assembly by means of the Adapter. The sleeve valve is then screwed into the Adapter.

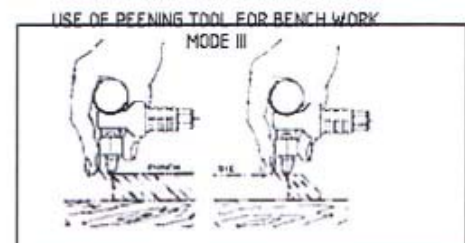
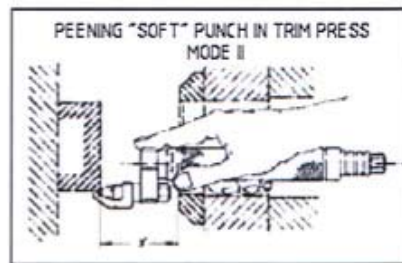
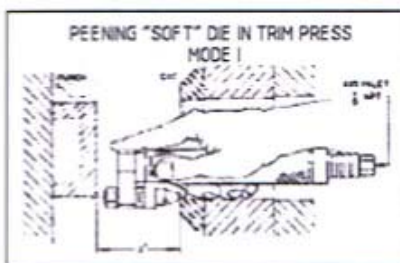

DIRECTIONS: The drawings above, show the operators hand reaching through the Bolster and through the center of the Die. The Punch is in it's retracted position and it will be noted that the 3" clearance between Punch and Die faces (3" stroke of the press) is ample clearance for the Peening Tool. The "soft" (40-45R"C") tool half is peened (also called "swagging") forcing the steel along the cutting edge to flow and thus close the clearance between Punch and Die. The tool's nozzle should be pressed against the work piece with SUFFICIENT FORCE to keep the tool from bouncing and the tool should be led slowly, guided by the Tracer, along the edge of the work piece as shown in the figures above. The peening action of the tool will cause the work piece (40 to 45R"C" Hardness) to swell in the desired manner and direction. The tool should never be held still, but should be guided along it's path at the rate of approximately 1/8 inch per second. At that rate the tool steel of the work piece will swell about .004" outwards. If more swelling is required, the above procedure can be repeated several times. Excess "peened" steel is then sheared away in the very first stroke of the press and upon removal of this "swarf" the tool is ready for work.

PISTON REPLACEMENT: In normal use a Piston will last a very long time. After extensive use, the tip of the piston will "mushroom" or otherwise lose it's precise spherical shape. A distorted piston tip will not give the proper swagging effect and should be replaced.

PARTS

MATERIALS AND CRAFTSMANSHIP: All moving parts of the Model 69 Universal Peening Tool are made of the most suitable alloy steel available and all parts are heat treated by the most advanced methods. Rigid tolerances assure complete interchangeability of spare parts.

MODEL 69 UNIVERSAL PEENING TOOL

COMPLETE TOOL:

This all-in-one kit contains the complete assembly, all conversion parts, wrenches, storage case, operating instructions and list of spare parts.

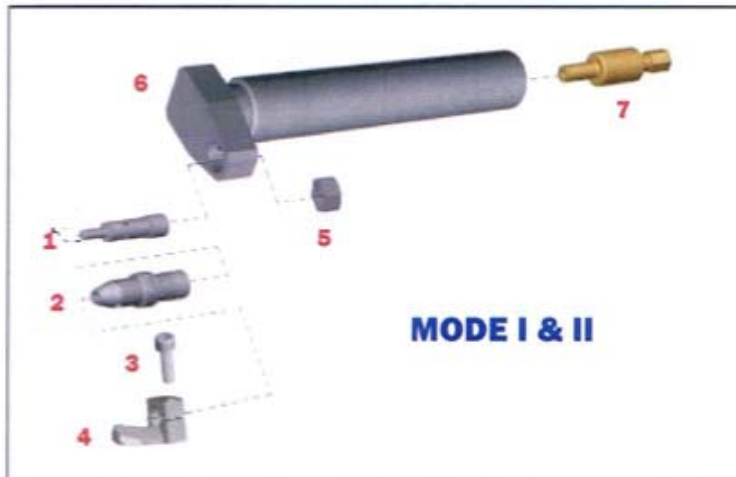

SPARE PARTS:

- 1 4101 Hardened Piston
- 2 4102/4103 Nozzle Bushing Assembly
- 3 4104 Socket Head Cap Screw
- 4 4105 Tracer
- 5 4106 Cap Nut
- 6 4107 Crank
- 7 4108 Sleeve Valve
- 8 4109 Handle
- 9 4110 Adapter
- 10 4111-9 Open End Wrench 9/16
- 11 4111-11 Open End Wrench 11/16
- 12 4112 Allen Wrench
- 4113 Tool Case

